

Product Brochure For Q2145

## Water Proof Dial Indicator - Precision - 34-2145

0-10mm



ORDER CODE:	Q2145
Range (mm):	0 - 10
Graduations (mm):	0.01
A (mm):	25
B (mm):	22
C (mm):	8
D (mm):	57
E (mm):	19
F (mm):	18
G (mm):	5
H (mm):	8

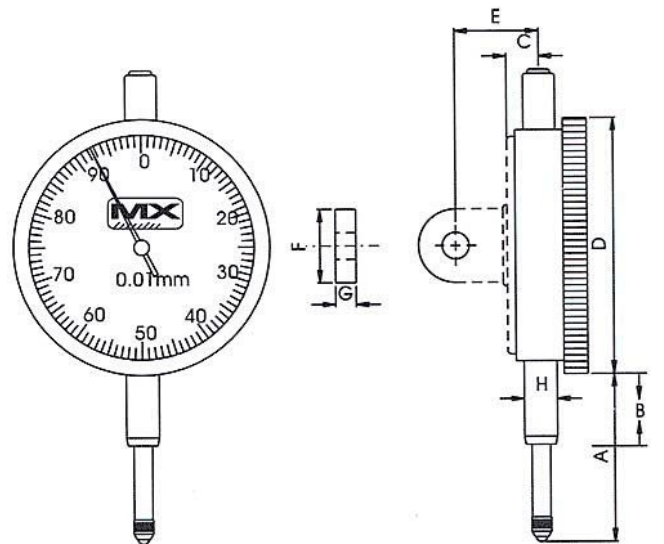

### Features

- Scratch and chemical resistant crystal
- Smooth movement with water proof design
- "O" ring set between the body and bezel
- Rubber boot over the spindle
- Flat back and back lug supplied
- Individual serial numbers with corresponding calibration certificate
- Supplied in plastic case

Product Brochure For Q2145

---

**Recommended Accessories**

M050  
Magnetic Base - Standard



M051  
Magnetic Base - Deluxe - One Lock



Q430  
Magnetic Base - Small



Q435  
Magnetic Base - Large



Q4351  
Magnetic Base - Large



Q436  
Magnetic Base - One Lock (Large)

